

Fill Cluster

Type 07004 - Fill cluster with check function



Cryogenic-Fill cluster, PN50

Bronze body and topwork
with check function and drain valve
"live loaded" gland packing
"cleaned and degreased for oxygen service"

Part No. 07004.X.7027

Fill connection: Mueller flange
Outlet: 2x complete with brazed stainless steel stubs acc. to ASTM A312
Non-return unit metal to metal seated, leakage rate D acc. to EN12266-1

Available options - on request only:

- brazed stainless steel stubs acc. to ISO 1127
- integrable strainer

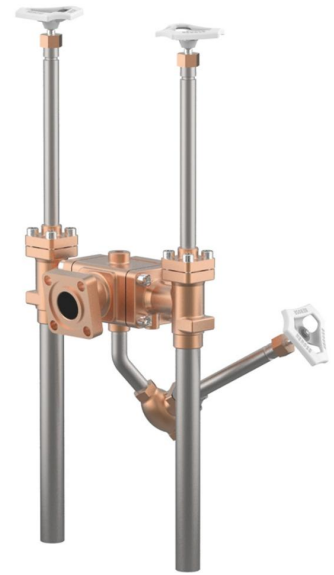

Applications:

Approved for air gases, vapours and cryogenic liquefied gases incl. LNG.
Working temperature: -196°C / -321°F (77K) up to +120°C / 248°F (393K)

Materials	DIN EN	ASTM
1 Fill body	CC491K	B 62 UNS C83600
2 Body	CC491K	B 62 UNS C83600
3 Valve seal	PTFE / Carbon filled (25%)	
4 Disc	CW614N	B 283 UNS C38500
5 Bonnet gasket	PTFE	
6 Headpiece	CC493K	B 505 UNS C93200
7 Bolts	1.4301/A2	A 194 B8
8 Elongation tube	1.4541	A 213 TP 321
9 Stem	1.4301	A 276 Grade 304
10 Gland packing	Graphite / PTFE	
11 Gland nut	CW614N	B 283 UNS C38500
12 Handwheel	Aluminium alloy	
14 Check disc	CW452K	B 159 UNS C51900
15 Spring	1.4571	A 313 Grade 316Ti
16 Cap	CC491K	B 62 UNS C83600
17 Stainless steel stubs	1.4306	A 312 TP304L

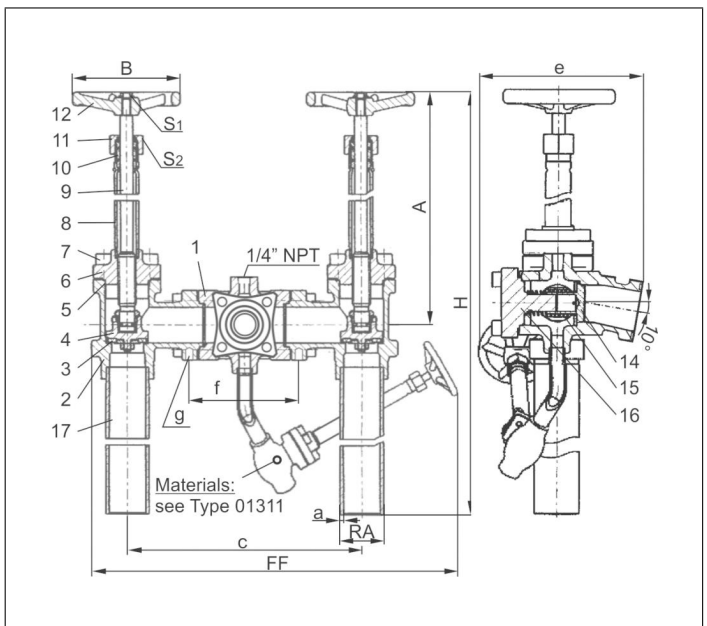

Standard marking acc. to Pressure Equipment Directive 2014/68/EU (PED).



Type 07004 - Standard design	Technical data		
Nominal size	DN	25	40
Dimension code	.X.	2533	4048
Face-to-face dimension	FF	340	340
Outside pipe-Ø ASTM A312	RA	33.40	48.26
Wall thickness pipe ASTM A312	a	dimensions acc. to S10 or S40	
Height	A	370	370
Height	H	735	735
Length	c	260	260
Length	e	235	245
Length	f	125	125
Thread	g	M10. 11 mm deep	M12. 13 mm deep
Handwheel-Ø	B	100	125
Wrench size across flats	S ₁	10	13
Wrench size across flats	S ₂	30	36
Weight	ca. kg	15.4	19.4

Dimensions in mm.